

# Subsea Intervention Daughter Craft



The KD Marine Daughter Craft provides an enhanced and highly efficient access system for Divers or ROVs around offshore production installations and facilities. They also facilitate diving to be performed from non-diving support vessels.

As well as being able to access difficult and remote positions they can also facilitate simultaneous working on multiple work faces thus increasing productivity.

The HYDRACraft 1500 is a 100% purpose designed Diving Daughter Craft outfitted for 3 x Diver Operations and complete with an independent LARS davit.

## Main Particulars

Length Overall:	14.4m
Beam Overall:	3.5m
Draft:	0.7m
Transport Height:	6.1m (cradle to wheelhouse)
In Water Height:	4.3m (waterline to mast top)
Weight (light ship):	8.5Te
Weight (full):	11.3Te
Davit Lifting Capacity:	15Te

## Performance

Loitering Speed:	6knts
Cruising Speed:	15knts
Max Speed:	21knts
Emergency Fuel (on board):	2 x 43L
Fuel Capacity:	390L
Fuel Consumption @ 6knts:	7LPH (each engine)
Fuel Consumption @ 15knts:	33LPH (each engine)
Fuel Consumption @ 21knts:	65LPH (each engine)

## Propulsion

Power Plants:	2 x Diesel VGT300 6.6L V8 Turbo
Power:	244kW/ 300HP each
Max RPM:	3500
Gearboxes:	2 x Hurth ZF-63C
Drives:	2 x Alamarin 288 Waterjet

## Deck Equipment

Anchor:	1 x 10kg
	1 x 7kg c/w 10mm chain
Mooring Bollard:	3.2Te
Towing Bollard:	3.2Te
Rope Spec:	8-Strand Nylon 12mm (3Te MBL)
Towing Line Spec:	8-Strand Polyester, 12mm (3.2Te MBL)
Fresh Water Supply:	60L Tank c/w Deck Supply

# Subsea Intervention Daughter Craft



## Safety Equipment

Life Buoys:	2 x Life Rings c/w lines
Life Jackets:	10 x 150N self-inflating type
Life Raft:	1 x 10 person self-inflating
Suits:	10 x Immersion Suits
Diver Recovery:	Diver Recovery Hoist
Flares:	6 x Parachute Type 6 x Handheld Type 2 x Smoke Type
Fire Extinguishers:	2 x 2.5kg Dry Chemical 1 x 1kg Dry Powder
Fire Suppression	MA2-450-227
EPIRB:	Sailor SE406-II
SART:	Simrad SA70

## Power Systems

Primary Generator:	Whisper Power M-SC10
Nominal Voltage:	230V ± 10%
Nominal Power Output:	9.4kW (40A) @ 3000RPM
Secondary Generator:	Whisper Power M-SC 3.5
Nominal Voltage:	230V ± 10%
Nominal Power Output:	3kW (13A) @ 3000RPM
Battery Charger:	Victron Energy Centaur
Voltage:	12V,
Current:	40A (max)
Battery Banks:	3 x 12V 120A/H
Shore Power:	230V ± 10%
Max Current Draw:	32A

## Medical Equipment

First Aid: Basic first aid kit; Medical Kit: SOLAS/ Lloyds Register Category C Medical Kit; Oxygen Administration Set: 540L

## Diving Equipment

Built in 3 Diver Nitrox / Air panel  
 1 x Nautronix 3520 Diver / Deck Communications  
 3 x 50-70m Diver umbilicals  
 2 x Panasonic DVRs and monitors  
 Resupply cables and hoses  
 Containerised suit drying and changing facilities  
 Containerised Twin Lock DDC

Analox Oxygen analysers  
 Divers dressing-in chair  
 3 x Kongsberg Sea Hawk Hemlet mounted CCTV system  
 Support equipment  
 Mooring hawsers and fenders  
 Containerised Haskell gas transfer pump  
 Containerised work shop and stores

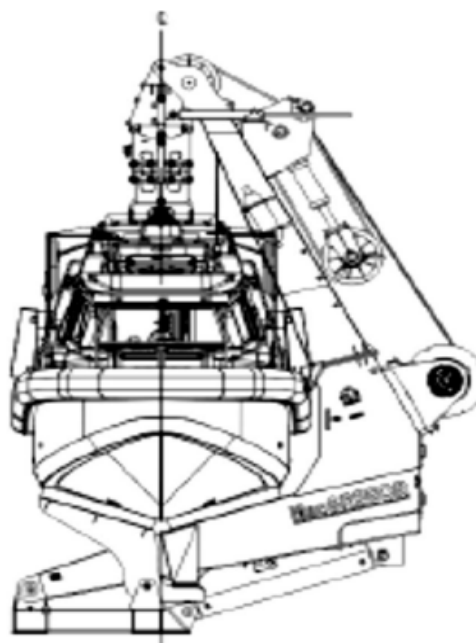
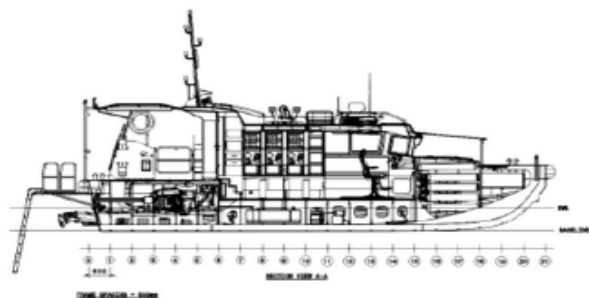
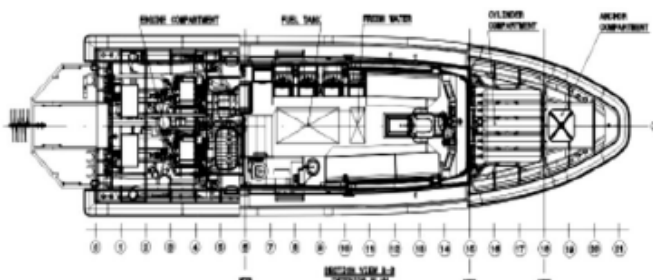

Safe

Reliable

Competent

Cost Effective